

# Ball bearing turntables and slewing rings

Ball bearing turntables are the product which started the success story of JOST in 1952. Today, they are used on all the world's roads. And not only that: They are also used in agriculture, at airports and railway stations, in mining and in a wide range of special applications, such as in TRIDEC forced steering systems.

In that way they are a genuine product of the JOST-World. They cover the whole range of trailer technology and offer the best solution for each application. At the same time, the ball bearing turntables are subject to constant further development, thus impressing with their innovative benefits and proven quality time and again.



## Design / Features

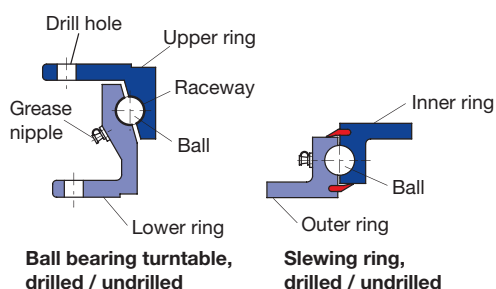

The ball bearing turntables and slewing rings allow the bogie to turn relative to the trailer frame. They transfer both the axial force and the thrust and tensile forces that occur while driving.

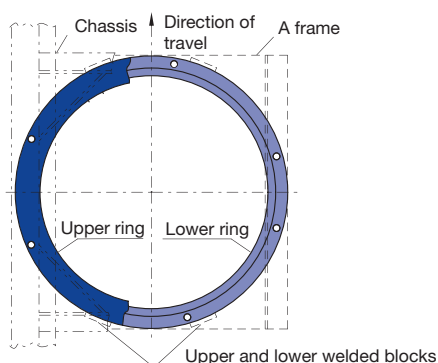

The lower ring/outer ring is bolted on to the A-frame and the upper ring/inner ring is bolted to the chassis. The A-frame, ball bearing turntable or slewing ring and chassis must never be welded together. Pre-welded stop blocks relieve the shear load on the bolts resulting from horizontal forces. JOST splined bolts can be used as an alternative where suitable, eliminating the need for additional welding of the thrust plates.

The ring must be mounted on a completely flat and rigid base with at least 50% of the circumference adequately supported.

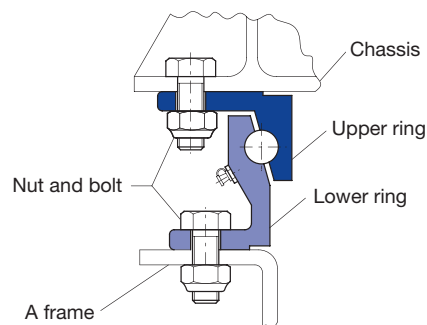

Ball bearing turntables are available as standard drilled and undrilled, slewing rings are available undrilled. Special drill templates are available upon request.

## Technical Features

### E-coating

- Premium corrosion protection
- Additional top coat on request

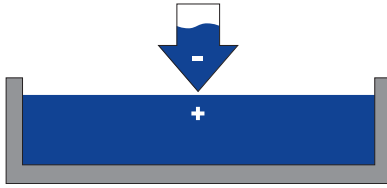

### Splined bolt

- Mounting kit with grooved screws, eliminating the need for additional welded thrust plates.
- Item number KLE 0000300 (16 pieces)  
Item number KLE 0000400 (24 pieces)



### Wear limit gauge KLE0005900

- The wear limit gauge KLE0005900 is suitable for JOST ball bearing turntables with a mounting height from 90 mm. It can be used to ascertain if a play/wear limit is reached or exceeded.



### Mounting kit KLE0000500

Item	Description	per kit
01	Hexagon bolt M16 x 1,5 x 55	16
02	Hexagon nut M16 x 1,5	16
03	Stop block	8

### Mounting kit KLE0000600

Item	Description	per kit
01	Hexagon bolt M16 x 1,5 x 55	24
02	Hexagon nut M16 x 1,5	24
03	Stop block	8

### Central lubrication manifold

- Makes lubrication easier
  - Makes connection to central lubrication system easier
- Item number KLE0000200



### High performance lubricant

- JOST high performance lubricant for initial greasing or follow-up lubrication
- Item number SKE005670000

## Maintenance

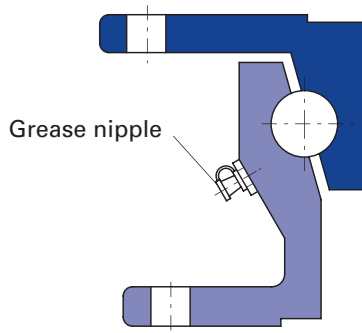

**Standard**

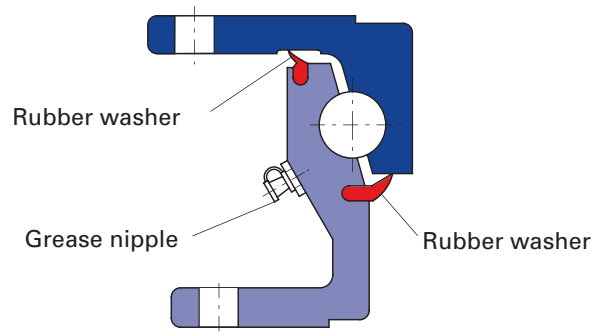

**Low-maintenance**

JOST standard ball bearing turntables are supplied with a thin base coating of lubricant. Before it is used for the first time the ball bearing turntable must be lubricated thoroughly. See JOST installation and operating instructions.

Connection to the central vehicle lubrication system is possible (grease is essential, no oil).

The low-maintenance versions of ball bearing turntables and slewing rings do not have to be maintained for up to three years or 300,000 km. After this period they must be serviced in the same way as standard turntables. The low-maintenance models are distinguished by a green type plate and by the letter "W" at the end of the item number. Maintenance conditions differ when fitted to steered semi-trailers or in the case of heavy conditions of use. The maximum storage period for maintenance-free ball bearing turntables and slewing rings is three years.

## Axial Load/Technical Notes

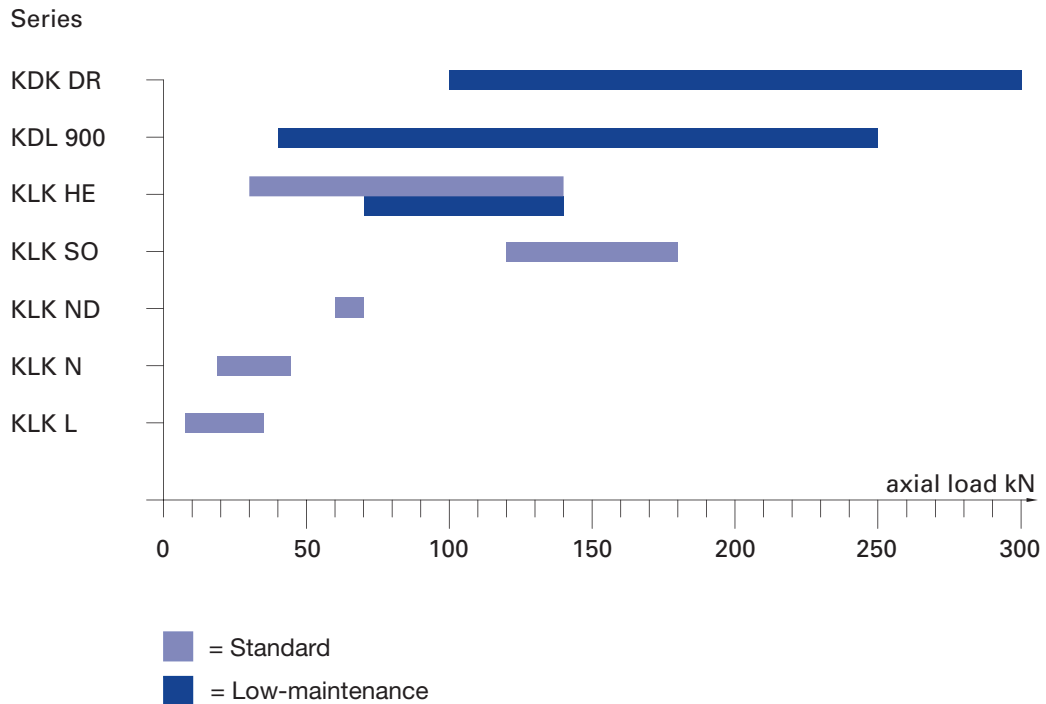

Ball bearing turntables and slewing rings are parts for fitting onto trailers and agricultural vehicles to connect the A-frame to the trailer chassis so it can swivel.

The range of applications for ball bearing turntables and slewing rings depends on the maximum axle load. JOST ball bearing turntables and slewing rings cover an axle load range from 7.5 to 250 kN.

The specified axle loads for series KDL, HE, SO, DR and ND are based on the pressure direction for three-axle vehicles with with turntable steering, travelling at a speed of up to 105 km/h. On dual-axle trailers, the specified axle loads can be exceeded by 10% or 20% at speeds below 30 kph (18 mph).

All load data for series KDL, HE, SO, DR, ND, L and N apply to use on roads in fifth wheel steering systems and for paved standard road conditions in Central Europe.

If the ball bearing turntables and slewing rings are to be mounted above the steered axle and above the king pin on semi-trailers, please ask JOST for the load data, giving details of the vehicle. Any deviations are given on the specification sheet.

Ball bearing turntables and slewing rings must always be operated as set out in the relevant operating instructions for the particular vehicle. Compliance with "TÜV" Safety Regulations and Motor Vehicle Safety Standards (StVZO) is required in Germany.

The axial loads specified are based on centric load introduction. Furthermore, the ball bearing turntables and slewing rings are only suitable for swivel movements. Please enquire about uses other than these.